

AWT-1000 Transfer Unit

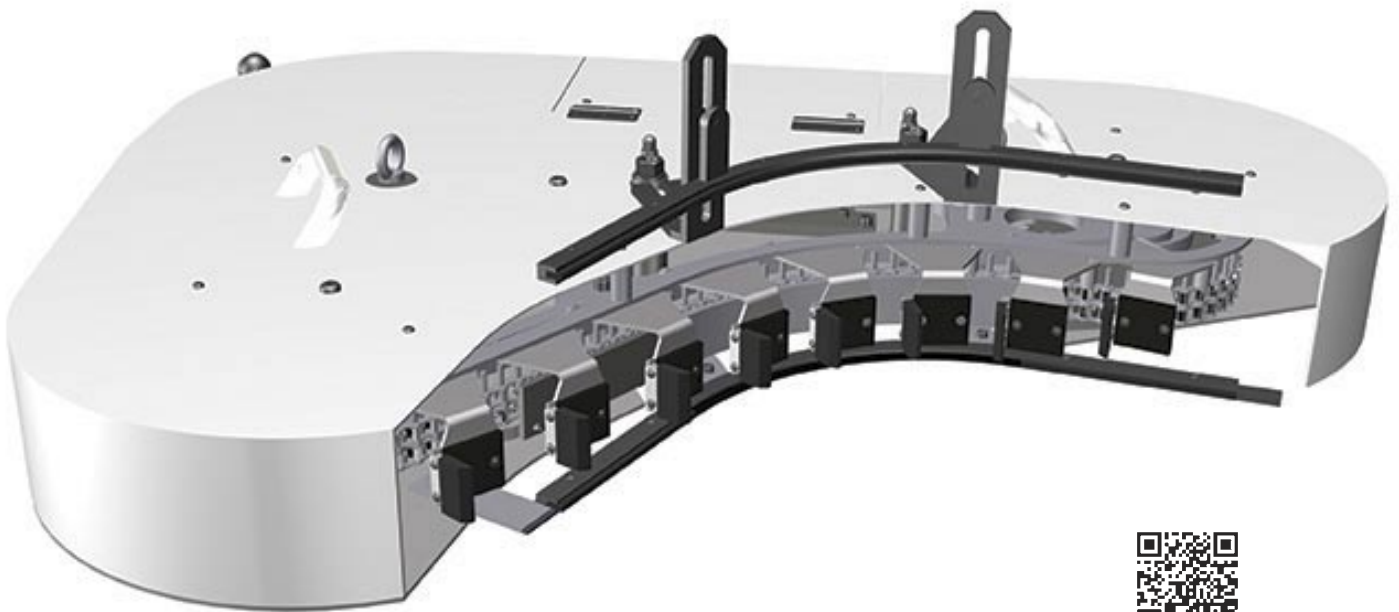

The AWT-1000 in design and concept is very similar to the HST-6000. This unit has a longer chain and has a different selection of finger spacings suitable for handling most types of production. Because of its chain length the transfer unit, while having the same curve profile as the HST-6000 is a larger transfer and is suitable for direct replacement of some competitors' older transfer units.

Features and Benefits

- 4 finger sizes
- 8 finger spacing configurations
- 'Quick Change' fingers
- Transfers containers from 40mm to 170mm diameter
- Adjustable top and bottom ware guides
- Spacing reduced by 40% through transfer
- Reduced job set-up time
- Enhanced container stability
- Reliable cross conveyor spacing
- Minimal spares holding
- Consistent ware handling up to 450BPM
- Intermediate fingers for 12 fingers and above
- For optimum performance we recommend use with Sheppee Cross Conveyor
- Recommended service intervals 12 months
- Carbon or SSB insulation

AWT-1000 Transfer Unit

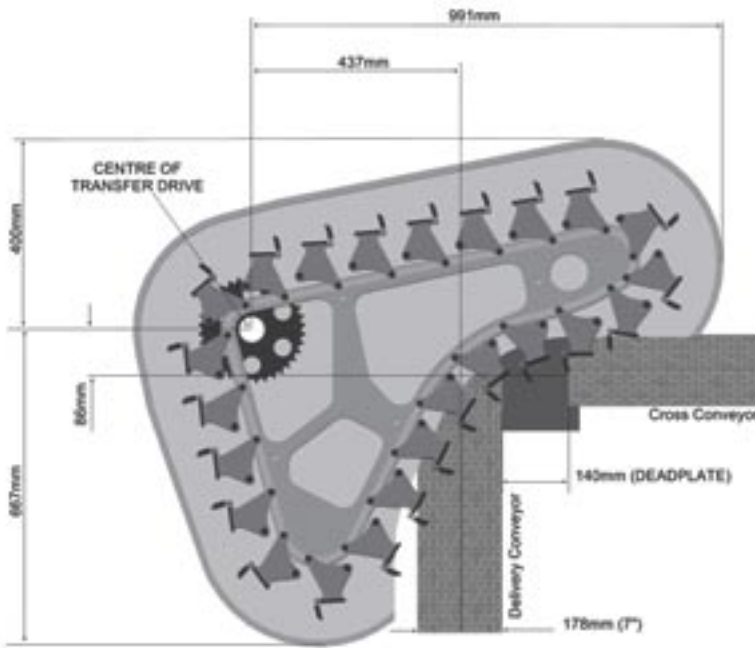

Technical Specifications

Operating speed:	Up to 450BPM
Standard chain length:	108"
Chain pitch:	3/4" Duplex
Number of teeth on drive sprocket:	30
Chain movement per revolution of drive shaft:	22.5"

Installation Details and Service Requirements

- Connection to Lincoln lubrication
- Can be driven by servo or synchronous motor drive
- Can work with all I.S. machine drive systems
- Transfer can be used in conjunction with a Sheppee ITD-8000-2 Transfer Drive Unit or STK-9284 Transfer Drive Gearbox

Chain Length Data

*see chart below

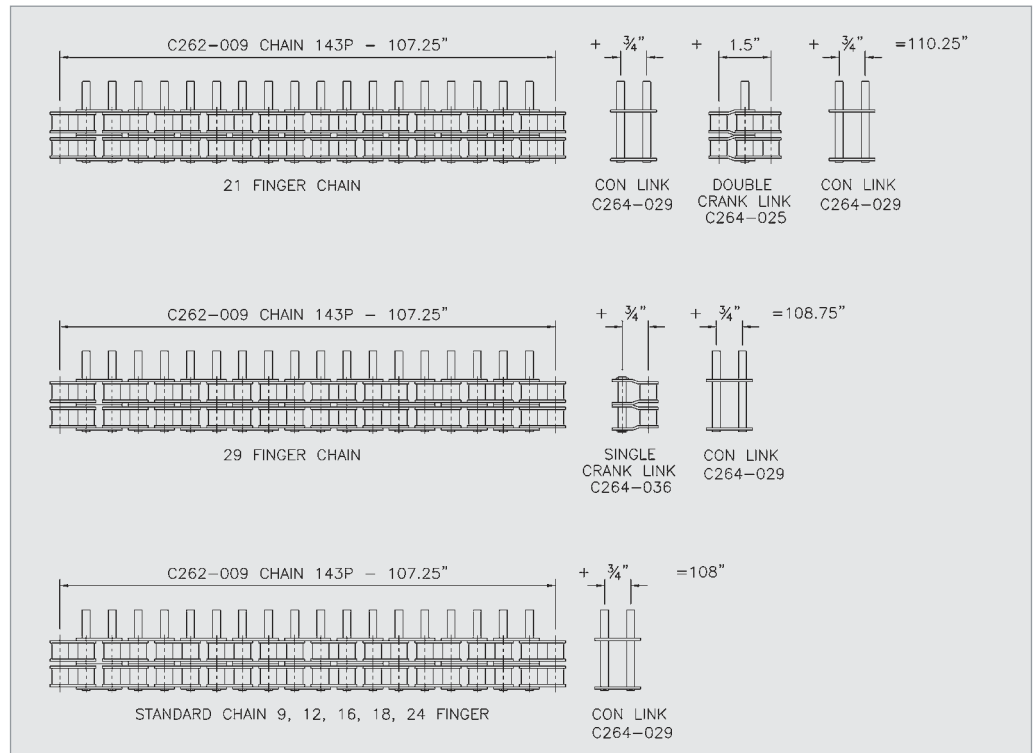

AWT-1000 Transfer Unit

Finger Spacing Options

Number of Fingers	Finger Spacing	Finger Part Number	Intermediate Finger Part Number	Container Size Limits
36	3"	HST-6021L/R		44mm
29	3 ³ / ₄ "	HST-6018-01-L/R		54mm
24	4 ¹ / ₂ "	HST-6018-01-L/R		66.5mm
		HST-6018-03-L/R		63mm
21	5 ¹ / ₄ "	HST-6018-03-L/R		74mm
18	6"	HST-6018-01-L/R		70mm
		HST-6018-03-L/R		82mm
16	6 ³ / ₄ "	HST-6018-03-L/R		98mm
12	9"	HST-6018-EXT-L/R	HST-6015-L/R	120mm
9	12"	HST-6018-EXT-L/R	HST-6015-L/R	165mm

*For SSB (stainless steel braid) option, add "-SSB" to the end of the part number.

** When using SSB insulation, container size limits should be reduced by 2mm.

Contact Material Options

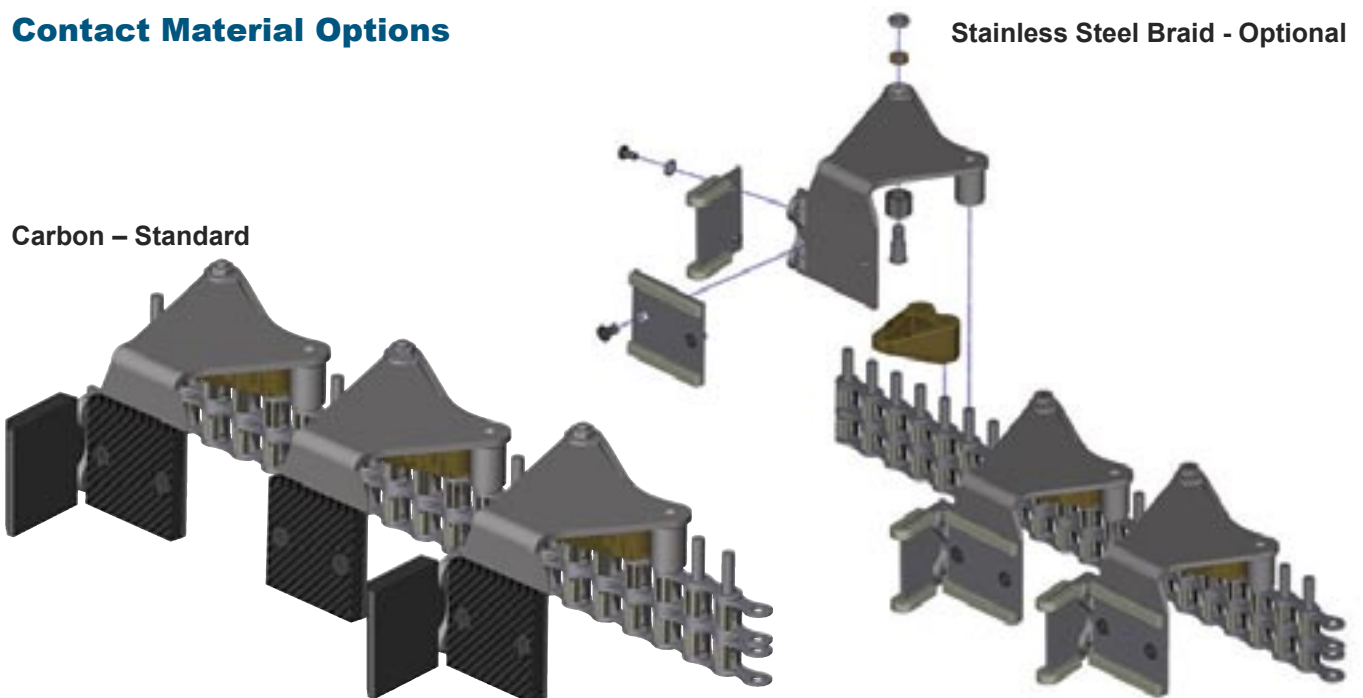

AWT-1000 Transfer Unit





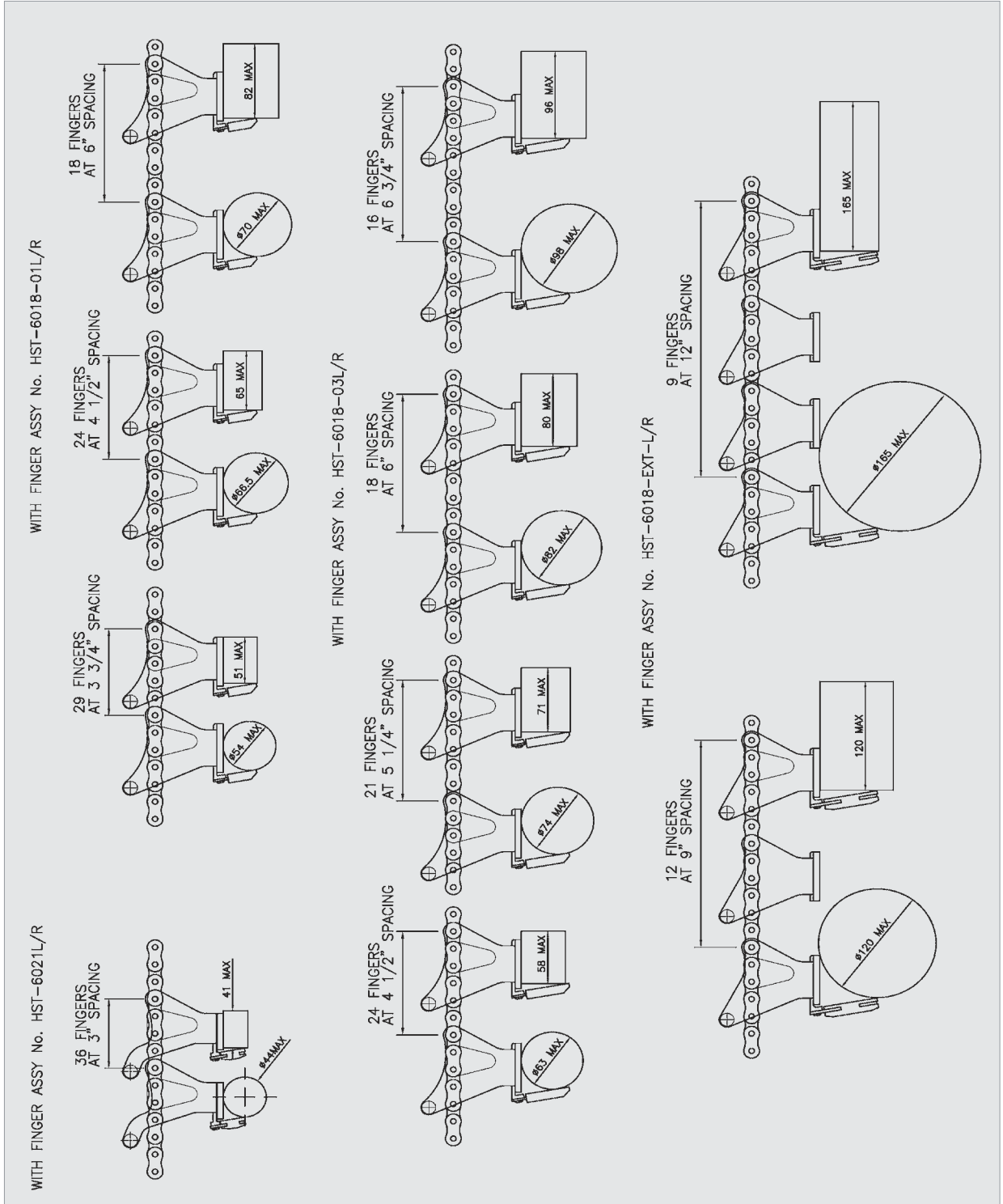









Container size limits

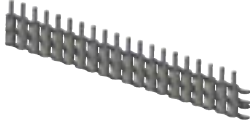

AWT-1000 Transfer Unit

Variable and Consumable Item Identification Chart Standard Finger Assembly

Part Number	Description	
HST-6018-01-L/R	Size 01 Finger Assembly	
HST-6018-03-L/R	Size 03 Finger Assembly	
HST-6021L/R	3" Spacing Finger Assembly	
HST-6015-L/R	Intermediate Finger	
HST-117-01	Size 01 Pusher Pad	
HST-117-03	Size 03 Pusher Pad	
HST-079	Back Pad	
HST-6021	Back Pad for 3" spacing	
C292-009	108" Chain	
AWT-113A	Upper/Lower Ware Guide	
AWT-113B	Upper Ware Guide	
AWT-113C	Lower Ware Guide	
HST-006	Finger Carrier	

For Stainless Steel Braid add SSB to the part number.
For all additional parts refer to assembly drawings.

AWT-1000 Transfer Unit



UK: Halifax Way, Airfield Business Park, Elvington, York, YO41 4AU
T: +44 1904 608 999 F: +44 1904 608 777
E: sales@sheppee.com

China: Sheppee-AP Sales & Support Centre, Shenzhen, China,
T: +86 755 8222 5976 E: sales@si-ap.com

www.sheppee.com